

# Simulation of a “Giannini True Reverber” vacuum-tube guitar amplifier by using wave digital filters

Thomaz Chaves de A. Oliveira<sup>1\*</sup>, Gilmar Barreto<sup>1</sup>,  
Alexander Mattioli Pasqual<sup>2</sup>

<sup>1</sup> Departamento de Semicondutores, Fotônica e Instrumentação  
Faculdade de Engenharia Elétrica e de Computação  
Universidade Estadual de Campinas, SP

<sup>2</sup> Departamento de Engenharia Mecânica  
Universidade Federal de Minas Gerais  
Belo Horizonte, MG

thomazchaves@gmail.com, gbarreto@dmcsi.fee.unicamp.br

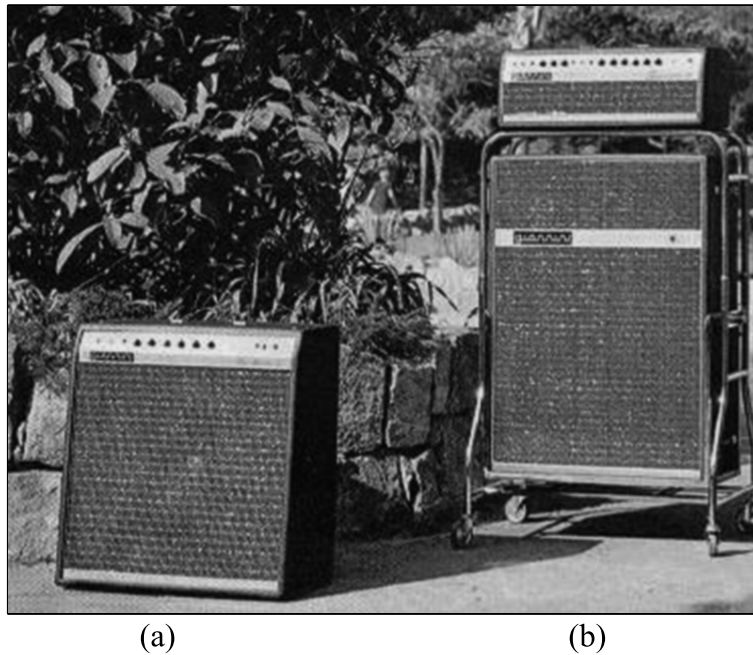
**Abstract.** *The objective of this work is to simulate a tube guitar amplifier, the Giannini True Reverber designed by Carlos Alberto Lopes in the nineteen sixties. The nonlinear “overdrive” characteristics of these devices make them attractive for guitarists since odd harmonics are added into the guitar sound as well as sound compression. The shortcomings of these amplifiers led to the development of DSP simulation techniques over the last few years. Many past DSP simulations of tube amplifiers were implemented using Static Digital Waveshapers for the task of replicating the tube transfer characteristics. Since the physical behavior of such systems is quite complex, physically informed models are necessary for more precision in the simulation, requiring more computer power. A Wave Digital Filter (WDF) simulation of the Giannini True Reverber double 12AX7 preamp is accomplished in this work using Koren’s triode equations and Block Compiler, where each parameter was acquired in the original electronic schematic or by measurement of the real amplifier. The real preamp is compared to the WDF model using the following test signals: single tone, logsweep and transient signal analysis. The results suggest that the current triode models do not cover all circuit topologies, so that further research is required.*

## 1. Introduction

One of the elements that characterizes the electric guitar sound is the amplifier that the guitar is connected to. The first amplifiers were made up of electron tubes or valves (European name), which were the electronic active devices that dominated the industry up to the 1970’s. Although the solid-state technologies have progressively replaced the vacuum tubes in most applications, these are still widely used in the electric guitar amplification. As a matter of fact, most of the guitar players prefer the valve amplifiers for their “warm” and “soft” sound [Bussey and Haigler, 1981, Oliveira et al., 2012, Barbour, 1998]. However, tube amplifiers — such as those shown in Figure 1 — are heavier, larger, less durable and more expensive than transistor amplifiers. This has motivated the development of devices that aim to emulate the timbral characteristics of vacuum-tube audio amplifiers. Because the interest in these devices is closely related to their nonlinear

---

\*Supported by CAPES.



**Figure 1: Vacuum Tube Electric Guitar Amplifiers - (a) Giannini True Reverber, (b) Giannini Tremendão, source [Giannini, 1962].**

behavior when overdriven [Hamm, 1973, Bussey and Haigler, 1981], there are no simple models that are able to accurately reproduce the tube amplifier sound, as observed by [Pakarinen and Yeh, 2009]. Many different techniques were proposed in recent years attempting to reproduce the sound characteristics of these devices via DSP, as covered in section 3.

This work's objective was to digitally emulate a Brazilian vacuum-tube amplifier designed in the 1960's by Carlos Alberto Lopes, the "True Reverber", manufactured by Tranquilo Giannini S. A.. This simulation used vacuum-tube equations obtained by [Koren, 1996] to resemble the triode tube's non-linear transfer and was implemented using Wave Digital Filters. It was not possible to model the entire amplifier due to its complexity, so only the first two triode 12AX7 stages in cascade configuration were implemented. All the circuit element characteristics such as capacitor values and voltages sources were either obtained from measurements from the real amplifier or by consulting the original circuit schematic. The digital virtual model was validated by a set of test signals, that were input in both the "Virtual Analog" digital amplifier and the real amplifier for the comparison of the outputs. The main objective was to test if such vacuum-tube emulation procedure can produce good sound reproduction of these devices when "overdriven" when using real circuit parameters, since many past work use non-circuit derived parameters, specially lower power supply voltages [Pakarinen and Karjalainen, 2010].

## 2. Giannini True Reverber

In recent years Brazilian made "vintage" tube amplifiers have been rediscovered by musicians. Since then, many amplifiers from the 1960's and 1970's have been restored by technicians to be used by the electric guitarists of the 21th century. One of the reasons for this is the electron tube comeback of the late 1990's [Barbour, 1998] and the fact that internet has enabled vacuum tube enthusiasts to gain knowledge on such circuits, in order for them to be restored back to proper working conditions.

The amplifiers developed by the Brazilian manufacturers from the 1960's and 1970's are characterized by their high standard of electronic components and tonal char-

acteristics, it is also worth noting that since most of them utilized 6L6GC as output tubes, these amplifiers excel in clean sound as opposed to EL34 output tubes amplifiers such as the ones produce by Marshall and other European brands. Another characteristic of these amplifiers are their high output power, ranging from 18 W to 300 W. In today standards, a amplifier output power rarely exceeds 100 W. As a consequence, amplifiers such as Palmer P200 and Giannini Tremendão are considered “*vintage*” relics, with prices around US\$1500.00, when these are either original or carefully restored to their original standards.

The amplifiers designed by Carlos Alberto Lopes and manufactured by Giannini equipped great names of Brazilian music of the 1960’s and 1970’s, such as the guitarists Pepeu Gomes, Sérgio Hinds from “O Terço”, and Sérgio Dias, lead guitarist of “Mutantes”. In this work, the simulation of a tube amplifier of this time is accomplished. The simulated amplifier is the 1965 Giannini True Reverber designed by Carlos Alberto Lopes in the 1960’s [Sabatinelli and Solon, 2004]. Figure 1 shows this amplifier on the left and the more famous Giannini Tremendão amplifier on the right, named after the famous artist Erasmo Carlos, who was known in the 1960’s as “Tremendão”. The technical specifications of the True Reverber II amplifier from 1965 are listed in Table 1.

Output Power	60W RMS
Preamp Tubes	3 x Miniwatt 12AX7
Poweramp Tubes	2 x RCA 6L6GC
Phase splitter	1x 12AT7
Tone Controls	Grave (bass), Agudo (treble) Volume, Brilho (bright switch)
Tremolo Controls	Velocidade (velocity), Intensidade (intensity)
Reverb Controls	Reverber (Reverb unit volume)
Switches	Liga (Power) and Fase (AC phase switch )
Connections	Entrada(input) Reverb Send, Reverb Return, Foot Switch, alto-falantes (speakers)
Input Impedance	680 k $\Omega$
Speaker impedance	4/8 $\Omega$
AC input	110V/ 220V (1960’s AC standard)
Dimensions	30cm x 72cm x 24,5cm

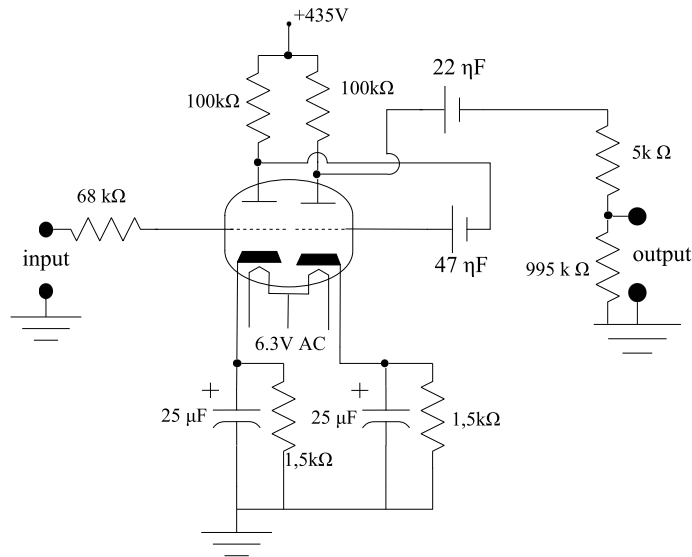
**Table 1: True Reverber II technical specs, source [Giannini, 1962].**

Figure 2 presents the Giannini True Reverber II pre-amplifier electronic schematic. In this circuit a double triode 12AX7 vacuum tube is the amplification device. This tube has two independent triodes inside its glass enclosure. This pre-amplifier circuit is a double common cathode circuit where the gain in each single triode stage is close to 70. The electric guitar is plugged into the grid of first triode of the 12AX7 (on the right), its signal receives a gain of 70 and the its output is injected in the grid of the second triode of the 12AX7 (on the left) thorough a coupling capacitor. The overall gain of this circuit is around 74 dB, and varies according to the tube’s manufacture, since vacuum tubes of the same type have significant variations. For more theory on vacuum tube amplification refer to Radiotron Handbook [Langford-Smith, 1953].

The DSP simulation theory for this type of circuit and related work is covered in the next section of this work.

### 3. Tube Guitar Amplifier Simulation

Since the modeling of vacuum tube amplifiers and analog effects possesses its own challenges, this research field has been called “Virtual Analog” [Pakarinen et al., 2011]. One



**Figure 2: Giannini True Reverber pre-amplifier schematic**

of the main advantages of virtual analog models is that many different amplifiers can be simulated in the same DSP (Digital Signal Processing) system by adjusting the simulation parameters [Pakarinen and Yeh, 2009].

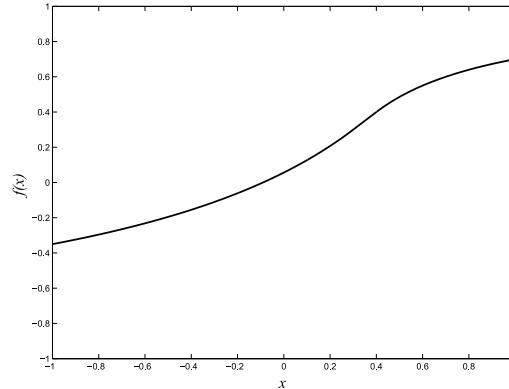
As far as amplifier simulation is concerned, the models must be categorized as either linear or nonlinear since analog amplifiers have corresponding linear circuits (RC or LCR filters) and nonlinear circuit elements (transistors, operational amplifiers, diodes and electron tubes). Unlike nonlinear systems, a linear system is characterized by its impulse response and does not increase the bandwidth of the input signal. From this point on, it is necessary to identify a circuit model as being linear or nonlinear. Digital models of linear circuits are mostly accomplished by the use of digital filters that recreate the frequency response of the corresponding analog filtering circuit. For digital models of nonlinear circuits, special functions must be used to generate the nonlinear transfer of these circuits. The nonlinearities will be considered in the next section and are the heart of tube amplifier sound simulations.

### 3.1. Nonlinear Digital Filters

The most straightforward way to generate nonlinear distortion in digital audio signals is by applying a nonlinear function into each sample of the signal, as illustrated in Figure 5. These functions can be of many types and are known as static waveshapers, where the term “static” is due to the fact that such waveshapers are memoryless systems. Waveshaping functions for audio applications were introduced by [Arfib, 1979] and [Le Brun, 1979] in the late 1970’s. Many simple DSP devices for tube amplifier simulation use waveshaping functions to generate the nonlinearities. Normally the waveshaping functions are run oversampled up to eight times the original sampling rate to avoid aliasing in the output signal [Pakarinen and Yeh, 2009]. An example of these functions was implemented by [Gallo, 2011] proposed in a patent that comprises a complex waveshaper to emulate the effects of vacuum-tube amplifiers:

$$f(x) = \begin{cases} \frac{(k_1 + x)}{(k_2 - x)}, & \text{if } x < a \\ x, & \text{if } a \leq x \leq b \\ \frac{(x - k_3)}{(x + k_4)}, & \text{if } x > b \end{cases} \quad (1)$$

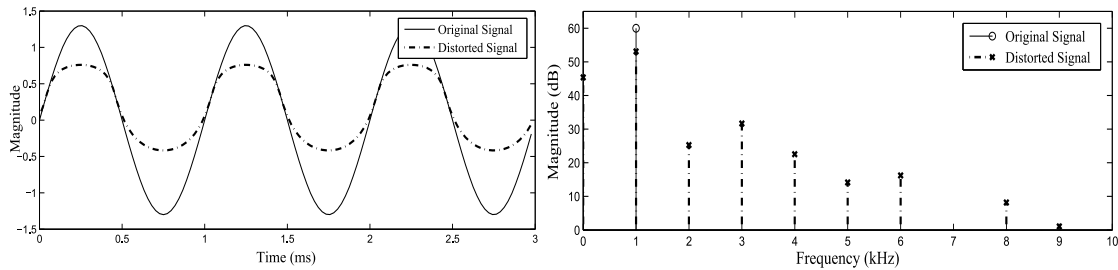
where  $k_1 = a^2$ ,  $k_2 = 1 + 2a$ ,  $k_3 = b^2$  and  $k_4 = 1 - 2b$ . The values of  $a$  and  $b$  can be freely chosen between  $-1.0$  and  $+1.0$  in order to control the characteristics of the nonlinear function. Since these two parameters are independent of each other, the positive and negative values of the input signal can be treated separately, which helps mimic the behavior of real vacuum-tube amplifiers. Small signals in the range  $a \leq x \leq b$  remain undistorted.



**Figure 3: Asymmetric wavelshaper proposed by [Gallo, 2011]**

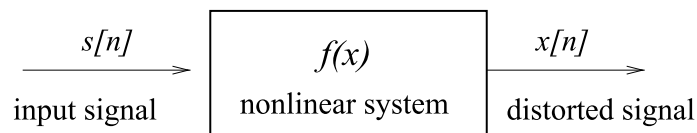
The wavelshaper of Eq. 1 is illustrated in Fig. 3, with parameters  $a = 0.3$  and  $b = 0.7$ . These parameters were chosen to highlight the asymmetric characteristic of this function.

Figure 4 exhibit the distortion introduced by Eq 1 into a 1 kHz test tone. It is worth noting that this asymmetric distortion introduces odd harmonics that have have larger magnitude than the even harmonics. Values  $a$  and  $b$  can be altered creating many different curves and distortion characteristics for Eq. 1.



**Figure 4: A 1 kHz sine wave filtered by Eq. 1 in the time and frequency domains with parameters  $a = 0.3$  and  $b = 0.7$ .**

The patent by [Gallo, 2011] also describes other parameters that can be added to this function to increase the system versatility, which are not presented in this paper for the sake of clarity. Benchmarks works for vacuum-tube amplifier simulations using waveshaping functions are present in the patents by Yamaha [Araya and Suyama, 1996] and Line Six [Doidic et al., 1998].



**Figure 5: Nonlinear system representation.**

## 4. Physically Informed Amplifier Models

In order to obtain better sound simulation of tube amplifiers alternative techniques have been developed over the last few years based on physical simulation of the amplifying circuits. In order to achieve this, it is necessary to convert a circuit schematic into a system of equations that correspond to the amplifier circuitry. Circuit elements such as capacitors, resistors and inductors are modelled directly using classical circuit equations whereas nonlinear circuit elements such as diodes, transistors and vacuum tubes are modelled with more complex equations to approximate their electric transfer.

### 4.1. Koren's Vacuum Tube Equations

Vacuum tube phenomenological equations, that is, equations that are not derived from fundamental physics but model the behaviour of a physical phenomena using fitted parameters were developed by [Koren, 1996]. These models were successfully used in most of the physically informed vacuum tube guitar amplifiers digital emulators developed over the last few years, and in SPICE (Simulation Program with Integrated Circuit Emphasis) simulations. Most physically informed vacuum tube amplifier simulations still use Koren's models [Yeh et al., 2010] [Macak and Schimmel, 2011] to model the nonlinear vacuum tube transfer. The triode equations are presented by Eq. 2 and Eq. 3:

$$E_1 = \left( \frac{E_p}{k_P} \right) \log \left( 1 + \exp \left( k_p \left( \frac{1}{\mu} + \frac{E_g}{\sqrt{k_{VB} + E_p^2}} \right) \right) \right) \quad (2)$$

$$I_P = \left( \frac{E_1 X}{k_{G1}} \right) (1 + \text{sign}(E_1)) \quad (3)$$

where  $E_p$  is the plate voltage,  $E_g$  is the grid voltage (where the electric guitar signal is applied),  $I_p$  is the plate current,  $k_{VB}$ ,  $k_p$ ,  $E_1 X$  and  $k_{G1}$  are fitting parameters that are altered according to the type of electron tube to be modelled. For that reason, Koren's triode equations are able to model many different triodes. In this model, the plate current is always  $I_p > 0$  for all positive plate voltages ( $E_p > 0$ ). Another important aspect of these equations is that grid current is absent, as the grid circuit's impedance is considered to be infinite. Novel equations developed by [Cohen and Helie, 2012] include the grid current, but have not yet shown their potential since they were developed very recently.

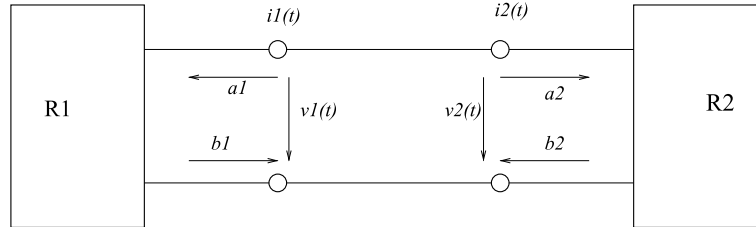
## 5. Wave Digital Filters

Wave Digital Filters (WDF) is a special type of digital filter that have a valid interpretation in the real world. This means that the behaviour of a physical and complex system can be modelled by this approach [Valimaki et al., 2006]. WDF have been used to create digital models of tube amplifiers over the last few years [Karjalainen, 2004, Karjalainen, 2005, Karjalainen, 2008, Pakarinen and Karjalainen, 2010].

The main advantages of this model methodology are: high modularization potential, energy preservation by the use of Kirchoff laws and good numerical properties in its implementations, leading to efficient real time digital models of virtual analog circuits for audio effects.

WDF were originally developed to solve lumped electronic circuits, by creating digital circuit models from the original schematic. Each circuit element is modeled by its circuit equation. The interconnection among elements is accomplished by WDF ports (adapters), in the same way as the original circuit. These adapters can either be serial adapters or parallel adapters.

The main characteristic of the WDF models is that the bidirectional interactions of circuit elements are considered. This is accomplished by the concept of wave scattering propagation. The formalism of WDF theory is based on ‘Voltage’ wave notations, in Equation 4,  $a$  corresponds to incoming wave and  $b$  corresponds to the reflected wave,  $V$  is the Voltage,  $I$  stands for current in the same ways as Kirchoff variables and  $R_p$  is the port or reference resistance, where all these variables are represented in Figure 6.



**Figure 6: Wave Digital Filters Signal Propagation of Kirchoff Variables.**

$$\begin{cases} a = V + R_p I \\ b = V - R_p I \end{cases} \quad (4)$$

The first WDF model of a triode common cathode amplifier was implemented by [Karjalainen, 2005]. The nonlinear tube characteristics is implemented by a nonlinear resistor implemented using Koren’s triode tube equation.

An enhanced version of this triode was accomplished by the same authors [Pakarinen and Karjalainen, 2010], where second order effects were added, such as blocking distortion and the Miller capacitance. The nonlinear processing core also used Koren’s triode models.

A particular digital WDF model for triodes was implemented for the Csound environment by [Fink and Rabenstein, 2011], where the classic comon-cathode stage circuit was implemented. The C-sound opcode was compiled into C code for real-time efficiency. This work also implements the nonlinear behavior of Koren’s triode equations.

A WDF simulation of a linear output transformer model with a triode amplifying power amplifier was reported by [Pakarinen et al., 2009]. This model does not include the nonlinear behaviour of the output transformer but was accomplished with the use of parameters for the speaker and transformer of real devices. In opposite way, a Wave Digital Filter Model of an output chain of power amplifier with a KT88 pentode in triode connection with an audio transformer was accomplished by [Paiva et al., 2011]. In this WDF model, the nonlinearities were introduced by the use of a gyrator and capacitor transformer model. The generated WDF model’s parameters were adjusted from measurements of two real transformers: a Fender NSC041318 and a Hammond T1750V transformers (both in single ended configuration). The model was also validated using these two real transformers. The nonlinearities of real audio frequency transformers are derived from hysteresis and core saturation. More details on WDF theory is covered by [Fettweis, 1986].

## 6. Nonlinear Audio Metrics

When a digital model is implemented, the comparison of both the analog and the virtual analog models must be made since the Digital Model is always a simplified version of the analog circuit. Special signal processing techniques have been proposed in order to compare output of different systems. One special testing methodology was created

by [Pakarinen, 2011]. This methodology uses single tone, intermodular, logsweep and transient signal analysis of a system's output signal and also the input signal. These techniques were used in a case study by [Oliveira et al., 2012] to characterize nonlinear distortion of an all tube Giannini True Reverber amplifier. Another common validation procedure is to use SPICE simulation of circuits and compare both output signals. Often a musician's trained ear is the best tool for judging either if a digital model performs its task in satisfactory way [Pakarinen and Yeh, 2009].

## **7. Giannini True Reverber WDF Model**

The digital WDF simulation of the True Reverber pre-amplifier was accomplished by the use of two WDF triode models. Each of these models are altered versions of WDF triode models originally developed by [Karjalainen, 2008]. These models use Koren's triode equations in order to produce the nonlinear transfer and high gain of the common-cathode triode amplifiers. The inclusion of real physical parameters derived from the original Giannini True Reverber schematic, obtained from [Giannini, 1980] and from measurements of the real amplifier enabled the creation of a new WDF model. This model has a cascade amplifying circuit that models the circuit of figure 2. The WDF representation of the Giannini True Reverber preamplifier is presented in Figure 7. The model was written in C-Lisp functional programming language and Compiled in the Block Compiler software by [Rabenstein et al., 2007] using the Lisp Works 6.0 environment. The implementation of the double triode stage uses a block approach where the implementation of the first amplifying block uses the input impedance of the second block as an additional parallel output impedance to the plate circuit. The output impedance of the second amplifying block is implemented by the addition of an additional parallel impedance that simulates the phase splitter input impedance on the original circuit. The simulation was executed at 96kHz to avoid aliasing into the audio bandwidth.

### **7.1. Test Signal Parameters**

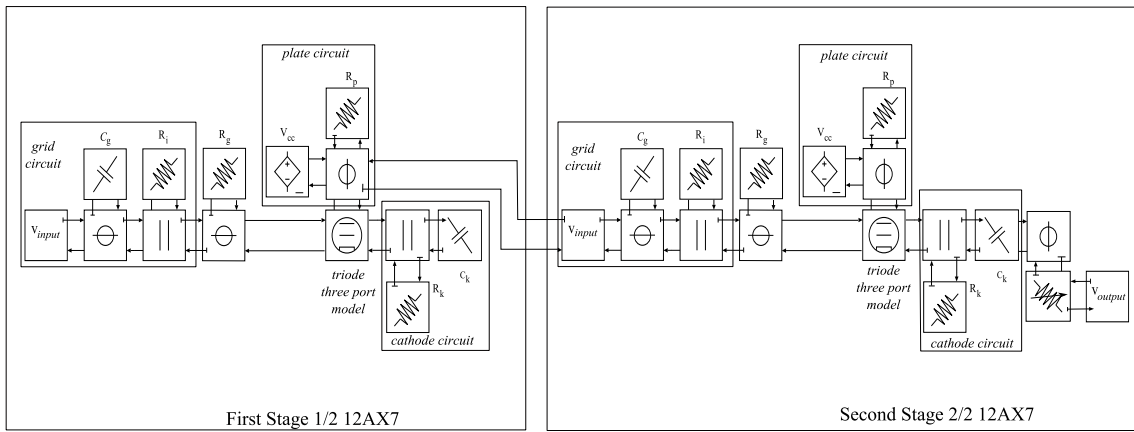
The test signals for the validation of the virtual True Reverber model were generated using the methodology developed by Pakarinen [Pakarinen, 2011] in order to compare the virtual pre-amplifier and the real pre-amplifier. All test signals were input in the virtual model and in the analog amplifier and were recorded using an Intel I3 2.53 GHz processor PC, with 3 GB of RAM with Windows 7 operating System and a Pro-tools M-Box audio interface. The single tone signal spectral analysis utilized 1 kHz sine wave as input to both real and virtual amplifiers. The logsweep analysis started from 20 Hz to 20 kHz in 2 s for five harmonics. Transient response analysis utilized a 1/10 ratio for 1 kHz signal and transient signal, for 2 s.

## **8. Results**

The inspection of Figures 9, 10 and 11 suggests that the virtual and real True Reverber pre-amplifier have distinct plot patterns for the test results. This suggests that WDF's and Koren's triode models led a simulation that does not match the real amplifier. [Pakarinen, 2011] and [Macak and Schimmel, 2011] also reported distinctive results when comparing real and virtual analog amplifiers.

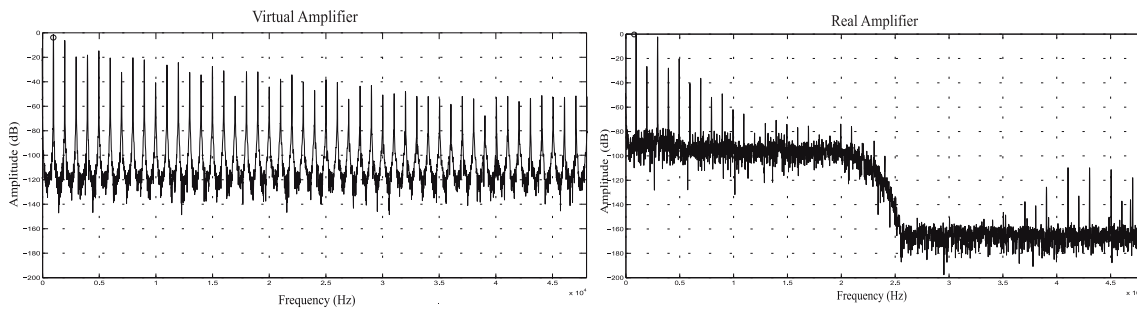
In most past virtual analog physically informed tube amplifier simulation studies [Karjalainen, 2004, Karjalainen, 2005, Karjalainen, 2008, Pakarinen and Karjalainen, 2010, Yeh, 2012], the authors compared the virtual amplifiers with SPICE simulation results for model validations, as opposed to this work that



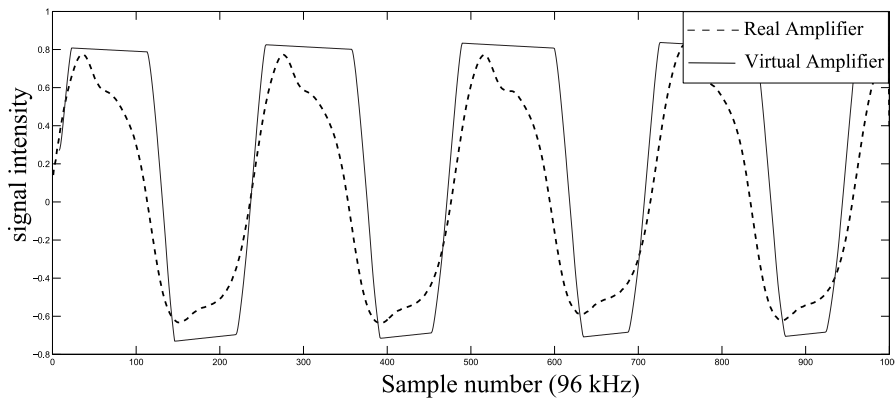


**Figure 7: Giannini True Reverber pre-amplifier WDF representation.**

compares a digital virtual amplifier to a real amplifier. This suggests that many models were biased since SPICE also uses Koren's triode equations for triode models and it is also a digital simulator. Another important aspect of the past cited works is that the power supply of these virtual circuits utilize lower voltages, such as 250 V. Koren's Equations were designed to work in that range, as opposed to most real amplifiers that operate in the 350 V - 450 V range. That might be the case for which none of these works make mention to any real amplifiers for reference. The simulation of the Giannini True Reverber amplifier was accomplished using parameters from the real schematic and measurements from the real amplifier (435 V power supply voltage), suggesting that in cases of real physical parameters the simulations may be unable to match the transfer of real tube amplifiers using Koren's triode Equations.



**Figure 8: Spectral Analysis of Real and Virtual Amplifiers**



**Figure 9: Time domain signals of distorted sine waves**

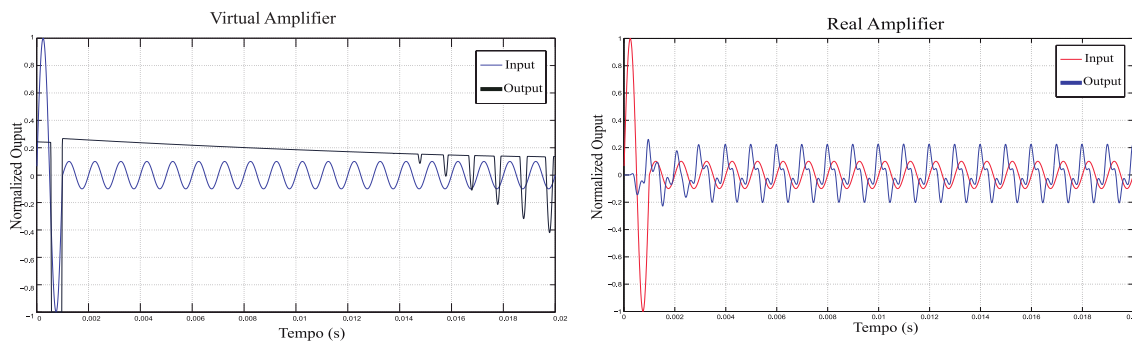


Figure 10: Transient Signal Analysis

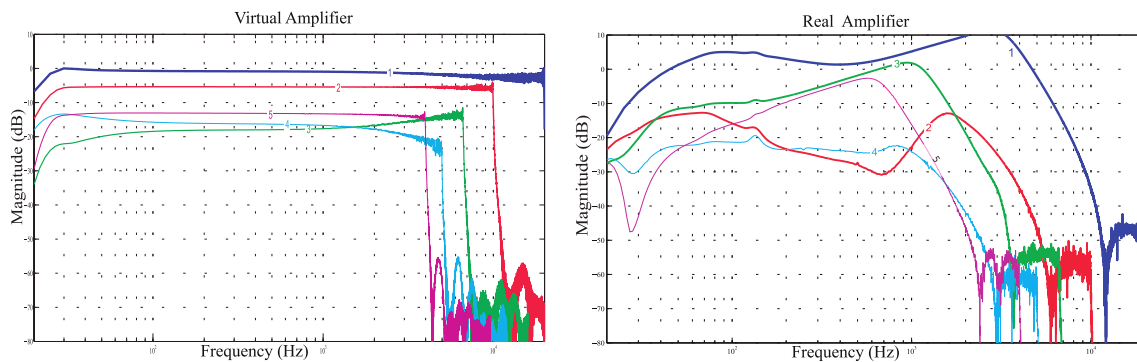


Figure 11: Logsweep Signal Analysis

## 9. Conclusions

In this work, results of Wave Digital Filters simulation using Koren's triode equations were unable to reproduce the transfer of a real amplifier, the Giannini True Reverber, suggesting that current Vacuum tube amplifier simulation techniques were unable to precisely match the sound characteristics of this amplifier. For real time simulations, there is always a trade-off between accuracy and computation time. Besides, more research should be conducted in order to derive a set of equations that will satisfactorily describe the physical behavior of vacuum tube amplifiers, as proposed by [Cohen and Helie, 2012], but these new triode equations have yet to prove their potential, since they were developed very recently. Finally, it is worth emphasizing that this work's results reinforce the psychoacoustic investigation conducted by [Macak, 2012a]. The quantitative data of this study describes that in 90 % of the blind tests, a trained listener can distinguish if a distorted "Crunch" guitar sound implemented in was either generated by a simulation program or by the actual physical analogue equipment. The same investigation for the Fender style "Clean" by [Macak, 2012b] sound also described that in 83 % of the blind tests the listeners were able to correctly identify if the sound was generated by a simulation program or the actual amplifier. Both this work and [Macak, 2012a] utilized Koren's vacuum tube equations, suggesting that these equations do not lead to digital simulations that can replace the vacuum tube amplifiers for trained listeners. This leads to the conclusion that vacuum tube amplifiers and related audio equipment will not be replaced by simulation programs in the near future. However this does not discard the emulation softwares as accessible tools for the simulation of these devices, as the simulations can be considered as satisfactory for the less trained listeners and musicians. The flexibility of these emulation tools is also an advantage over expensive, large, heavy and hard to handle vacuum tube amplifiers. It is also worth noting that these simulation softwares can be utilized as a sound reference tool for musicians to be acquainted to the classic electric guitar vacuum tube sound.

## References

- Araya, T. and Suyama, A. (1996). Sound effector capable of imparting plural sound effects like distortion and other effects. U.S. Patent no. 5570.424.
- Arfib, D. (1979). Digital synthesis of complex spectra by means of multiplication of nonlinear distorted sine waves. *Journal of the Audio Engineering Society*, 27(10):757–768.
- Barbour, E. (1998). The cool sound of tubes - one of the last remaining tube domains is in music applications, but there the devices flourish and even innovate. *IEEE Spectrum*, 35(8):24–35.
- Bussey, W. and Haigler, R. (1981). Tubes versus transistors in electric guitar amplifiers. In *Acoustics, Speech, and Signal Processing, IEEE International Conference on ICASSP 1981*, pages 800–803, Atlanta, Georgia, U.S.A.
- Cohen, I. and Helie, T. (2012). Measures and models of real triodes, for the simulation of guitar amplifiers. In *Proceedings of the Acoustics 2012 Nantes Conference*, Nantes, France.
- Doidic, M., Ryle, M., and Senffner, C. (1998). Tube modeling programmable digital guitar amplification system. U. S. Patent no. 2004.0258.250.
- Fettweis, A. (1986). Wave digital filters: Theory and practice. *Proceedings of the IEEE*, 74(2):270–327.
- Fink, M. and Rabenstein, R. (2011). A csound opcode for a triode stage of a vacuum tube amplifier. In *Proceedings of the 9th International Conference on Digital Audio Effects (DAFx-11)*, pages 1–6, Paris, France, 2011.
- Gallo, M. N. (2011). Method and apparatus for distortion of audio signals and emulators of vacuum tube amplifiers. U.S. Patent no. 2011/0033057.
- Giannini, T. G. S. A. (1960-1980). Esquemas eletrônicos dos amplificadores valvulados da giannini. Electronic Schematic scanned from “Esquematoteca da Rua Aurora”-Santa Ifigênia, São Paulo-SP.
- Giannini, T. G. S. A. (1962). Catalogo da eletrônica giannini. Printed Catalogue of Giannini Products.
- Hamm, R. O. (1973). Tubes versus transistors-is there an audible difference. *Journal Audio Engineering Society*, 21(4):267–273.
- Karjalainen, M. (2004). Discrete-time modeling and synthesis of musical instruments. In *Joint Baltic-Nordic Acoustics Meeting*, Mariehamn, Åland, Finland.
- Karjalainen, M. (2005). Recent advances in multi-paradigm modeling. In *Forum Acusticum*, Budapest, Hungary.
- Karjalainen, M. (2008). Efficient realization of wave digital components. *IEEE Transactions On Audio, Speech, and Language Processing*, 16(5):738–746.
- Koren, N. (1996). Improved vacuum tube models for spice simulations. *Glass Audio*, 8(5):18–27.
- Langford-Smith, F. (1953). *Radiotron Designer’s Handbook*. Wireless Press RCA Victor Division, Radio Corporation of America.
- Le Brun, M. (1979). Digital waveshaping synthesis. *Journal of the Audio Engineering Society*, 27(4):250–266.

- Macak, J. (2012a). Real-time digital simulation of guitar amplifiers as audio effects. Ph. d. thesis, Brno University of Technology - Faculty of Electrical Engineering and Comunication - Department of Comumnications.
- Macak, J. (2012b). Simulation of fender type guitar preamp using approximation and state-space model. In *Proceedings of the 12th International Conference on Digital Audio Effects (DAFx-15)*, York , U.K.
- Macak, J. and Schimmel, J. (2011). Real-time guitar preamp simulation using modified blockwise method and approximations. *EURASIP - Journal on Advances in Signal Processing*, 2011(629309):1–11.
- Oliveira, T., Barreto, G., and Pasqual, A. (2012). Analise de distorcao nao linear em amplificadores de audio valvulados. In *XXIV Encontro da SOBRAC*, Belem-PA, Brazil.
- Paiva, R., Pakarinen, J., Valimaki, V., and Tikander, M. (2011). Real-time audio transformer emulation for virtual tube amplifiers. *EURASIP - Journal on Advances in Signal Processing*, 2011(347645):1–15.
- Pakarinen, J. (2011). Distortion analysis toolkit a software tool for easy analysis of nonlinear audio systems. *EURASIP - Journal on Advances in Signal Processing*, 2011(617325):1–15.
- Pakarinen, J., Abel, J., Fontana, F., Lazzarini, V., and Valimaki, V. (2011). Musical applications of real-time signal processing. *EURASIP - Journal on Advances in Signal Processing*, 2011(108):1–2.
- Pakarinen, J. and Karjalainen, M. (2010). Enhanced wave digital triode model for real-time tube amplifier emulation. *IEEE Transactions on Audio, Speech, and Language Processing*, 18(4):738–746.
- Pakarinen, J., Tikander, M., and Karjalainen, M. (2009). Wave digital model of the output chain of a vacuum-tube amplifier. In *Proceedings of the 12th International Conference on Digital Audio Effects (DAFx-09)*, Como , Italy.
- Pakarinen, J. and Yeh, D. T. (2009). A review of digital techniques for modeling vacuum-tube guitar amplifiers. *Computer Music Journal*, 33(2):85–100.
- Rabenstein, R., Petrausch, S., Sarti, A., De Sanctis, G., Erkut, C., and Karjalainen, M. (2007). Block-based physical modelig for digital sound synthesis. *IEEE signal Processing magazine*, 24(2):42–54.
- Sabatinelli, R. and Solon (2004). Da válvula ao simulador. *Áudio Música e Tecnologia*, (150):55–65.
- Valimaki, V., Pakarinen, J., Erkut, C., and Karjalainen, M. (2006). Discrete-time modelling of musical instruments. *Reports on Progress in Physics*, 69(1):1–78.
- Yeh, D. T. (2012). Automated physical modeling of nonlinear audio circuits for real-time audio effects - part ii: Bjt and vacuum tube examples. *IEEE Transactions on Audio, Speech, and language Processing*, 20(4):1207–1216.
- Yeh, D. T., Abel, J. S., and Smith III, J. O. (2010). Automated physical modeling of nonlinear audio circuits for real-time audio effects - part i:theoretical development. *IEEE Transactions on Audio, Speech, and language Processing*, 18(4):728–737.